

Intrinsically safe network power supply and isolator ZS-31EEx1

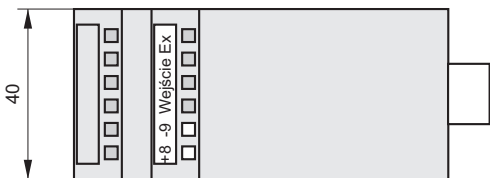

- ✓  II (1)G [EEx ia] IIC **Ex-rated**
I (M1) [EEx ia] I
intrinsically safe
- ✓ **Full galvanic separation of circuits (IN-OUT, IN-SUPPLY, OUT-SUPPLY)**
- ✓ **Accuracy 0.1%**
- ✓ **Casing can be mounted on a standard rail (TS35, TS32)**

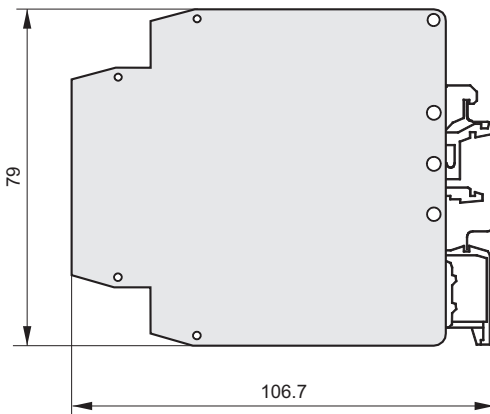
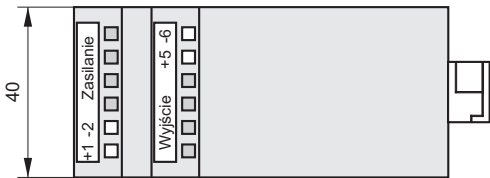

Application and functions

The ZS-31EEx1 power supply and isolator is a partially intrinsically safe device with an external (input) intrinsically safe circuit.

The ZS-31EEx1 is designed to supply power intrinsically safe transmitters used in a hazardous area, with a 4...20 mA signal in a two-wire transmission, and to transform that signal through a galvanic separation circuit into one of the standard signals used in automatic control.

The supply voltage of the intrinsically safe input circuit of the standard version of the ZS-31EEx1 is 20 V DC. At the customer's request this voltage can be altered to 16 or 18 V DC.

The output circuit can be connected to any apparatus with a separated supply voltage of < 250 V (from transformer-based network supplies).

Calibration

The user can adjust the setting of the start-point and width of the range using potentiometers accessible via marked holes in the front panel.

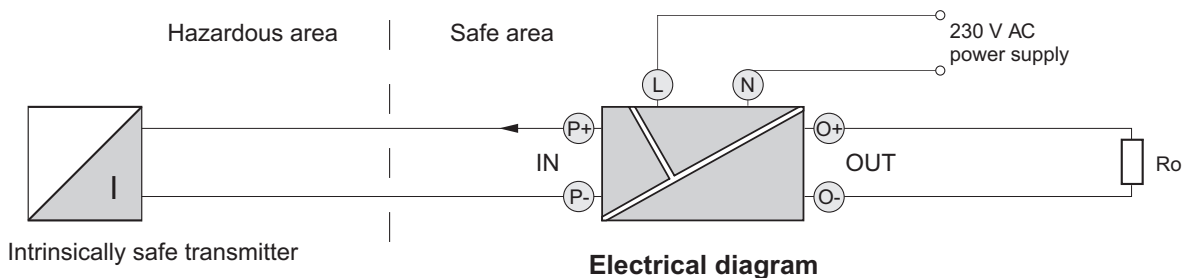

Technical parameters

- Input parameters

Input signal from the transmitter 4...20 mA

Standard version

Supply voltage of the input circuit U_{IN}	16 V	18 V	20 V	22 V	24 V
Maximum voltage on the terminals of the input circuit U_0	16.8 V	18.9 V	21 V	23.1 V	25.2 V

Input voltage after loading by the transmitter with output signal 4...20 mA
 U_{IN20} is the supply voltage of the input circuit

$$U_{IN20} = U_{IN} [V] \cdot 0.75$$

Maximum shorting current of input circuit $I_0 = 105 \text{ mA}$

- Output parameters

Output signal	Output load resistance
4...20 mA	500 Ω
0...20 mA	500 Ω
0...5 mA	2 k Ω
0...5 V, 1...5 V, 0...10 V	10 k Ω

Standard version

- Galvanic separation

IN-OUT optoelectronic
 IN-SUPPLY, OUT-SUPPLY network transformers
 Test voltage between circuits 2.5 kV AC, 50 Hz or equivalent DC

- Conversion errors

Accuracy 0.1%
 Non-linearity $\pm 0.05\%$
 Effect of temperature fluctuations $\leq \pm 0.1\% / 10^\circ\text{C}$
 Effect of load resistance fluctuations $\leq \pm 0.05\%$
 Effect of supply voltage fluctuations $\leq \pm 0.1\%$

- Dynamic characteristics

Time constant c. 0.05 s (by arrangement: 0.1...1 s)

- Power supply

Supply voltage rated: 230 V AC $\pm 10\%$
 Maximum power $\leq 4 \text{ VA}$

- Conditions of normal use

Ambient temperature 5...60°C
 Relative humidity 30...80%

- Casing

Ingress protection rating IP 20

- Weight

0.35 kg

Ordering procedure

Standard version ($U_{IN} = 24 \text{ V}$, output 4...20 mA): **ZS-31EEx1**

Special version: **ZS-31EEx1 /** **/**

Input circuit voltage

Output signal

Important: For transmitters in version ALW with switched on illumination of display and used internal resistor 250 Ω should be specified model ZS-31EEx/24V/25.2V.